

11 - SCHEMATICS

Table of Contents

	Page No
Schematics (Table of Contents) .....	12-1
ac4a-14 (1) RF - BB .....	12-2
ac4a-14 (2) RF - RF 0.37 CPH (Connections between RF & BB modules) .....	12-3
ac4a-14 (3) RF / HAGAR .....	12-4
ac4a-14 (4) RF / POWER AMP.....	12-5
ac4a-14 (5) SYS ac4a (DCT4 Common BB) .....	12-6
ac4a-14 (6) SYS / AUDIO (Audio Interface) .....	12-7
ac4a-14 (7) SYS / EMU (Test and Emulator interface) .....	12-8
ac4a-14 (8) SYS / EMU / JTAG (Testpoints for JTAG Emulator) .....	12-9
ac4a-14 (9) SYS / EMU / OSTRICH (Testpoints based Ostrich interface) .....	12-10
ac4a-14 (10) SYS / IR (IR module based implementation) .....	12-11
ac4a-14 (11) SYS / KEY (User interface) .....	12-12
ac4a-14 (12) SYS / LPRF (Power RF interface) .....	12-13
ac4a-14 (13) SYS / MEMORY AMD64 (Burst Read / Write) .....	12-14
ac4a-14 (14) SYS / MEMORY / MEMFILTER (Discrete capacitors for memory without VFlash1).....	12-15
ac4a-14 (15) SYS / POWER (Dual power management) .....	12-16
ac4a-14 (16) DCT4 Power Supply (Light filtering) .....	12-17
ac4a-14 (17) SYS / Production Test Pattern .....	12-18
ac4a-14 (18) SYS /RF - BB (GSM RF BB interface) .....	12-19
ac4a-14 (19) SYS / SIM (SIM reader) .....	12-20
ac4a-14 (20) .SYS / SYS CONN (System connector) .....	12-21
ac4a-14 (21) SYS / UPP (UPP 8M implementation) .....	12-22
ac4a-14 (22) .SYS / UPP / UPP FILTER (Discrete decoupling capacitors for UPP) .....	12-23

ac4a-14(1) RF - BB

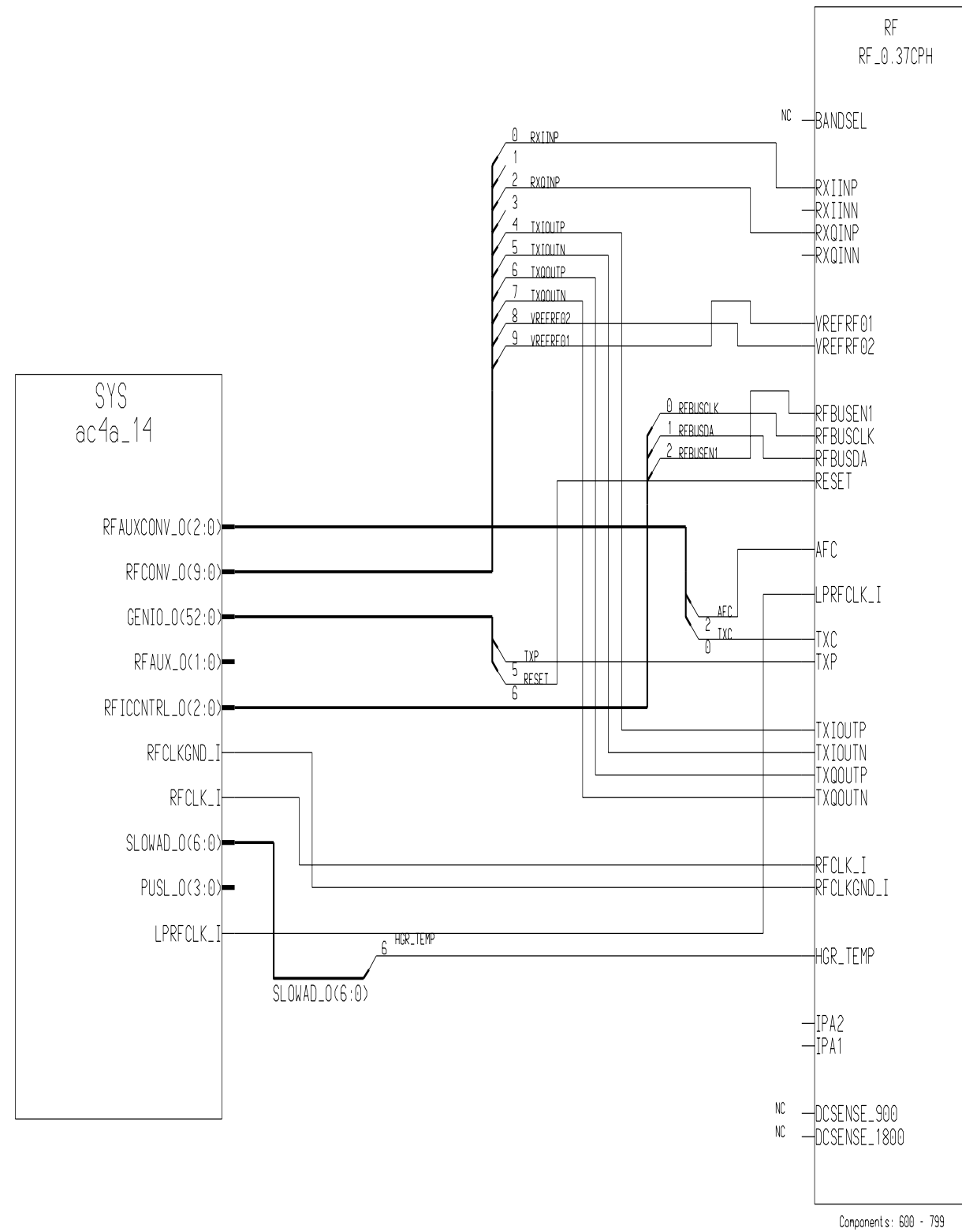

ac4a-14(2) RF - RF 0.37 CPH (Connections between RF & BB modules)

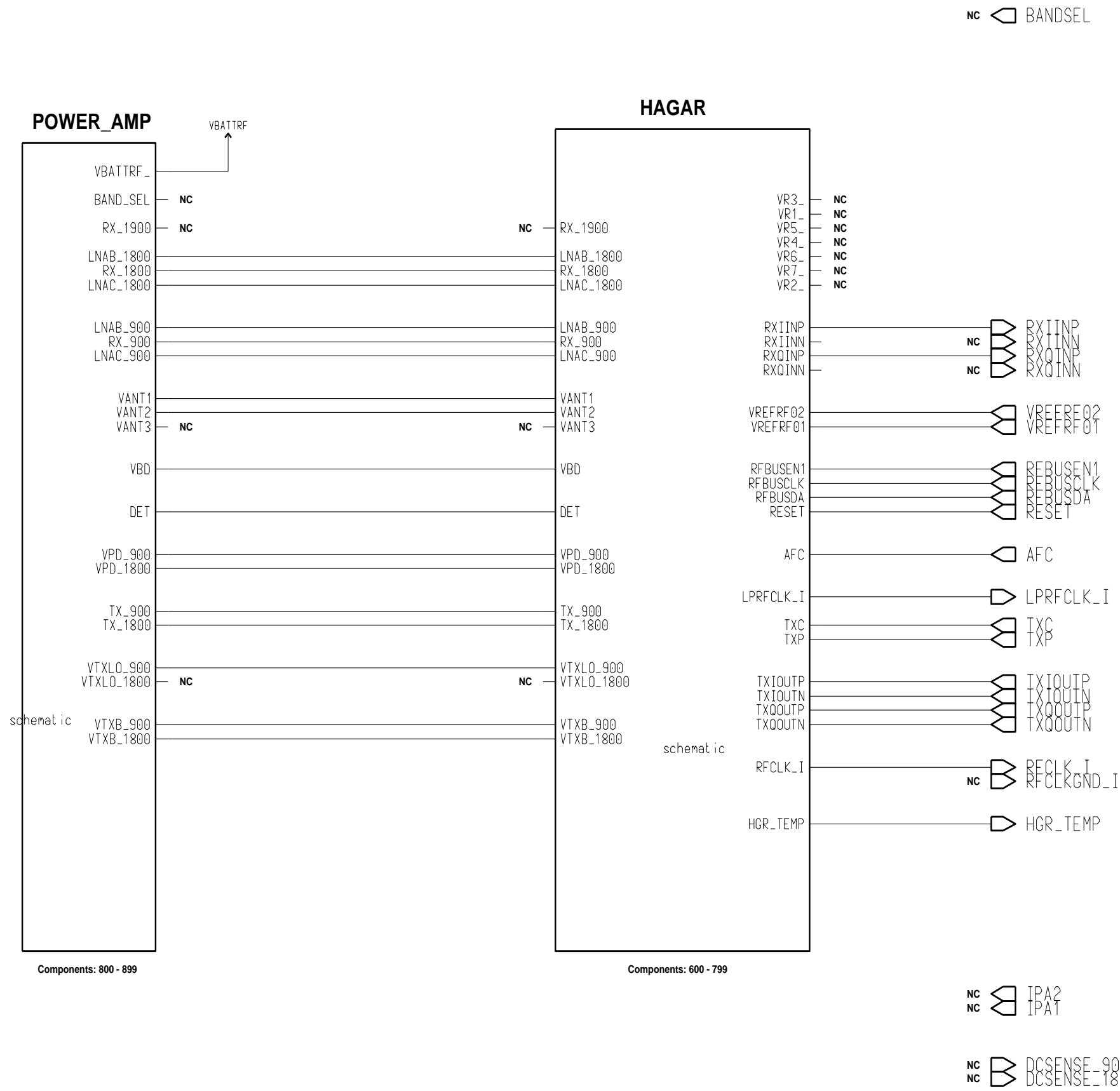

ac4a-14(3) RF / HAGAR

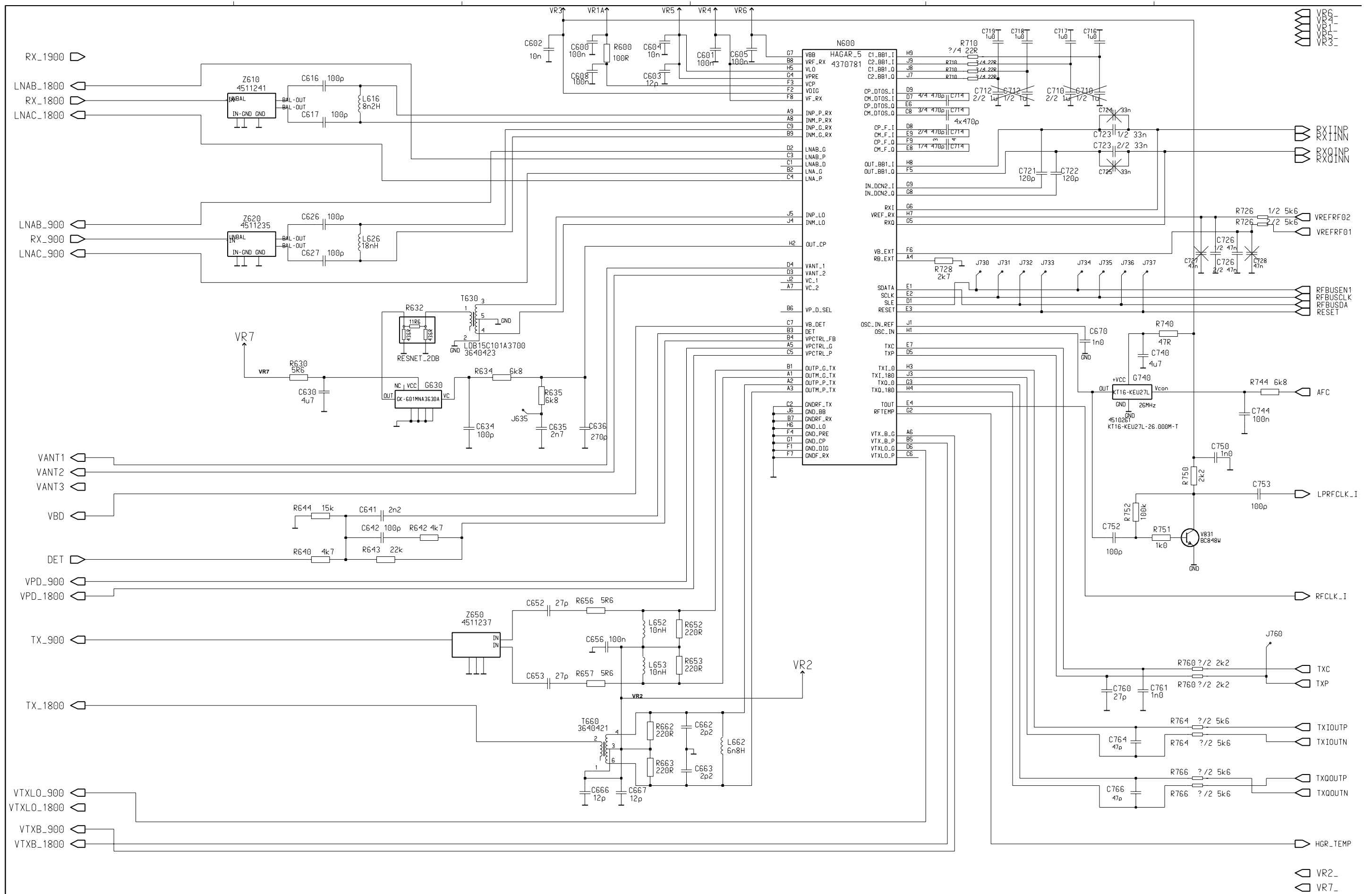

ac4a-14(4) RF / POWER AMP

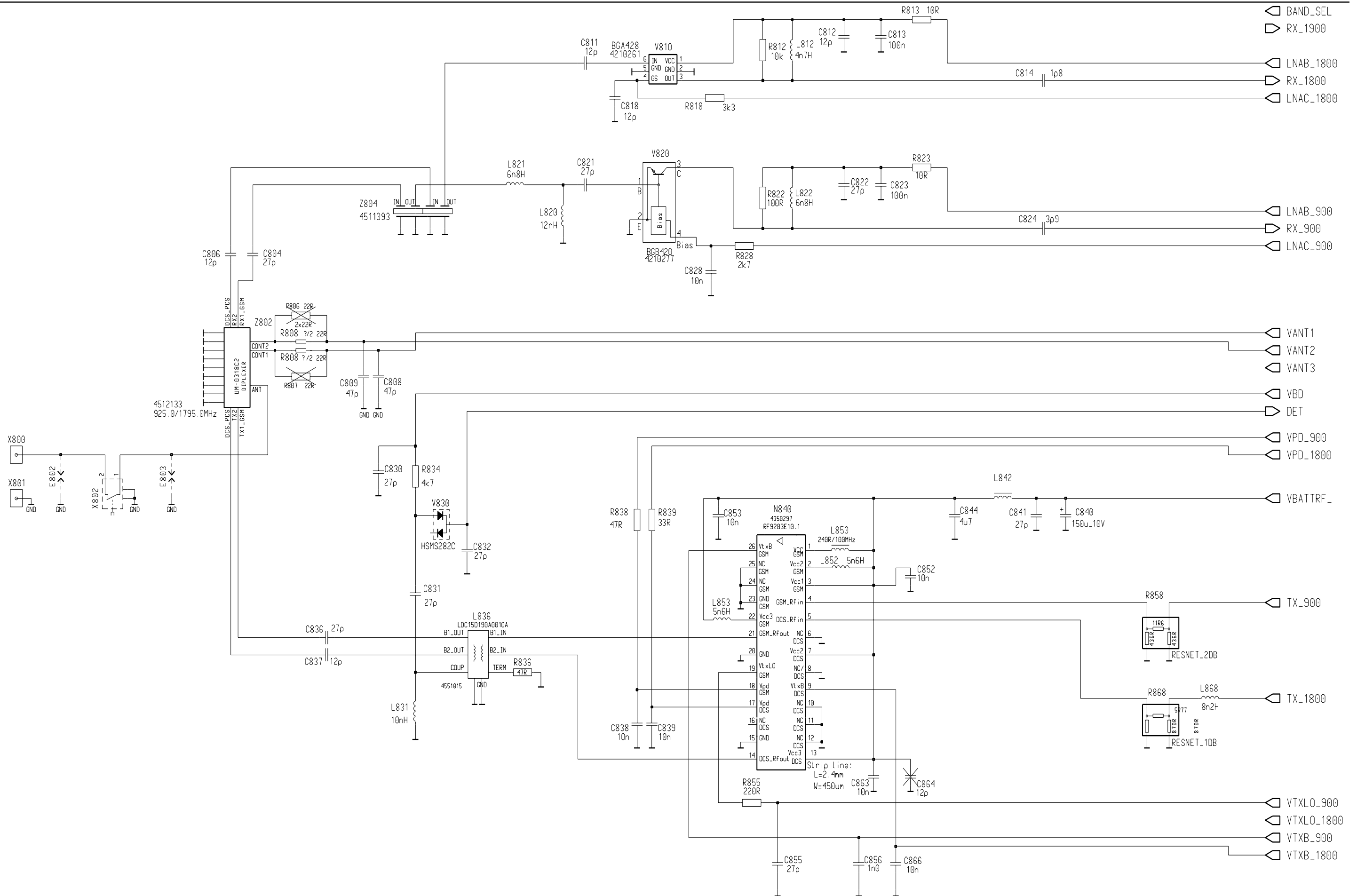

ac4a-14(5) SYS ac4a (DCT4 Common BB)

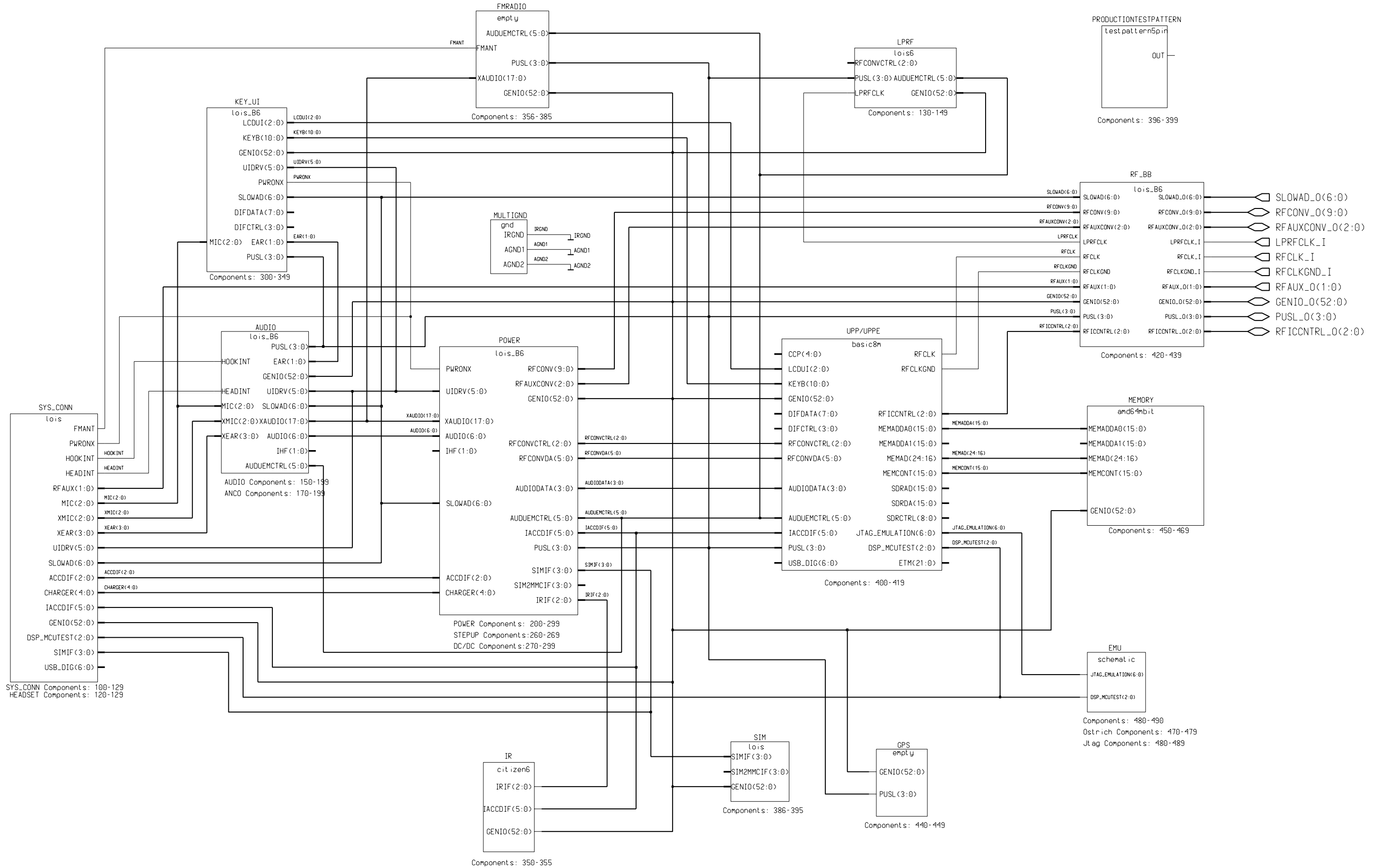

ac4a-14(6) SYS / AUDIO (Audio Interface)

AUDUEMCTRL<5:0>

SLOWAD<6:0>

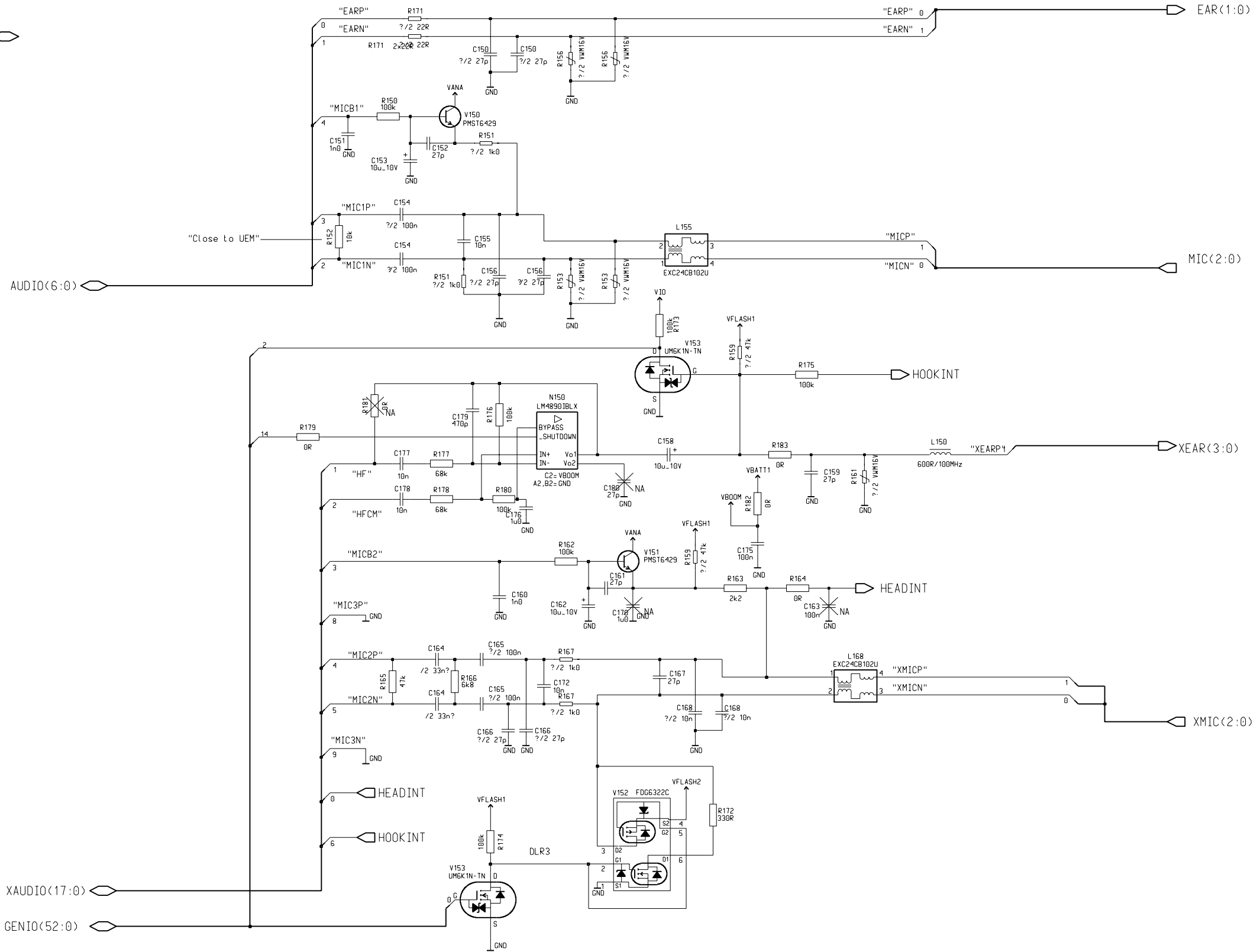

PUSL<3:0>

UIDRV<5:0>

IHF<1:0>

EAR<1:0>

MIC<2:0>

XEAR<3:0>

XMIC<2:0>

XAUDIO<17:0>

GENIO<52:0>

ac4a-14(7) SYS / EMU (Test and Emulator interface)

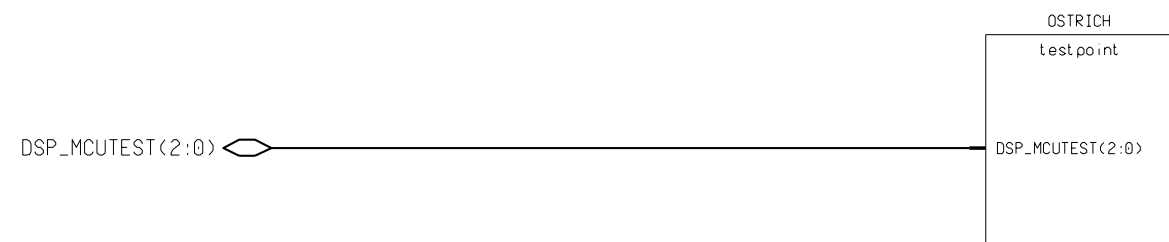



ac4a-14(8) SYS / EMU / JTAG (Testpoints for JTAG Emulator) .

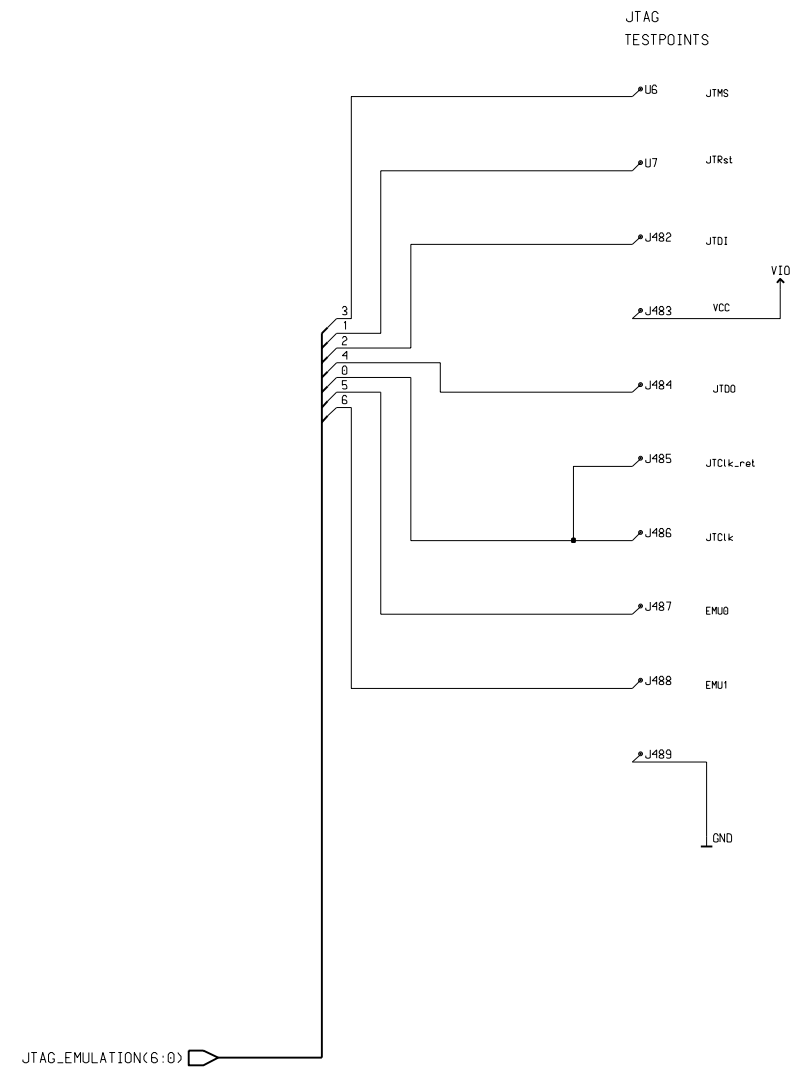

ac4a-14(9) SYS / EMU / OSTRICH (Testpoints based Ostrich interface)

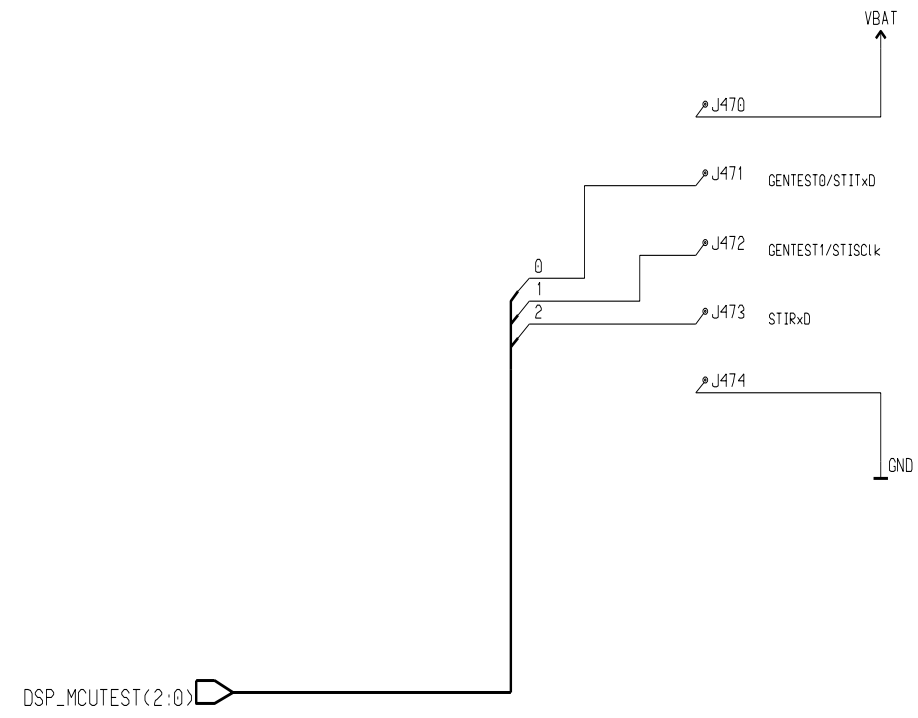



ac4a-14(11) SYS / KEY (User interface)

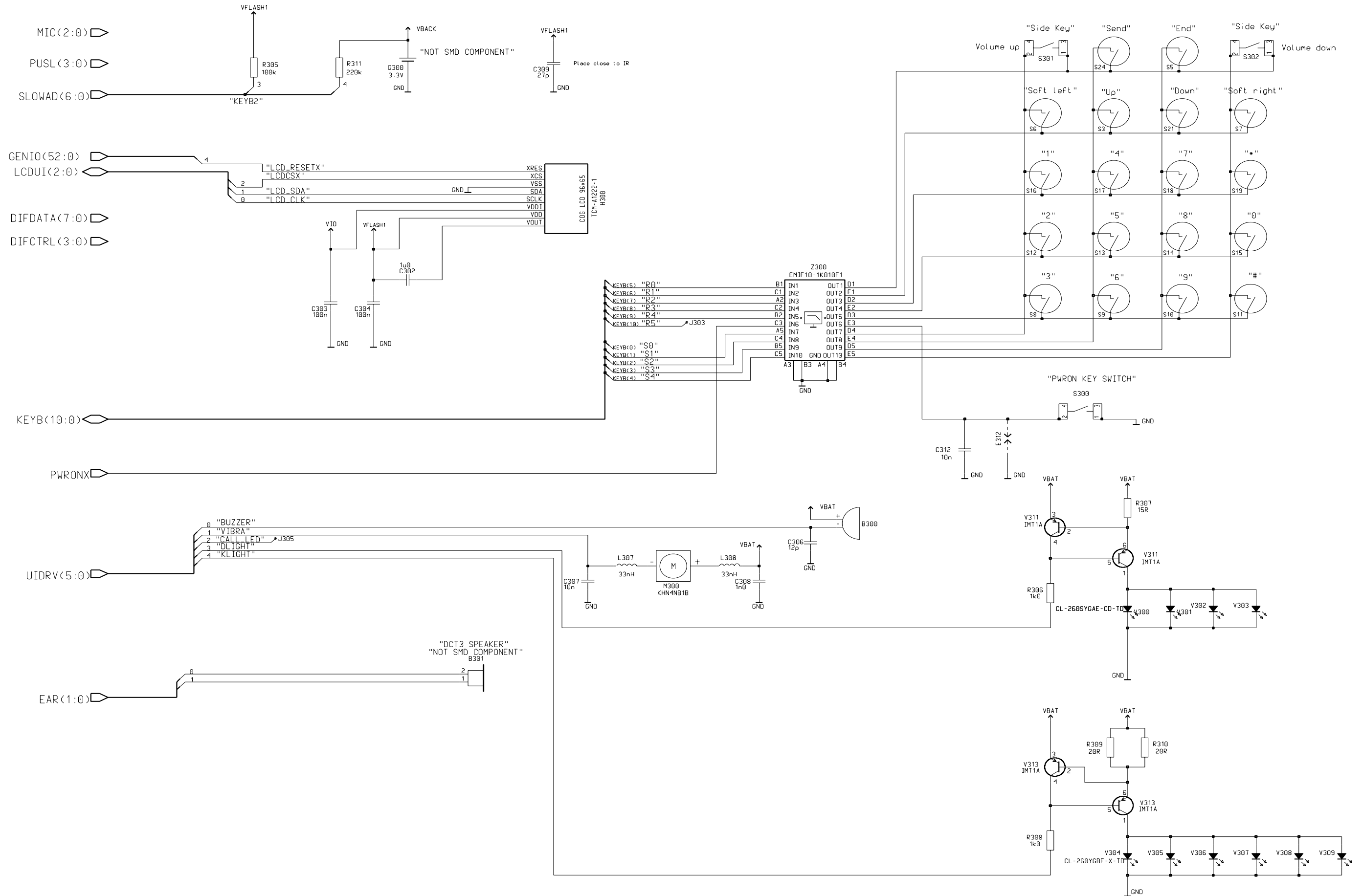





ac4a-14(14) SYS / MEMORY / MEMFILTER (Discrete capacitors for memory without VFlash1).

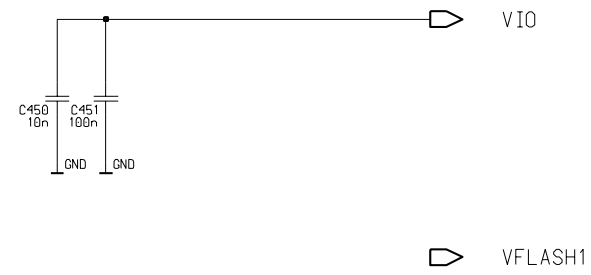

ac4a-14(15) SYS / POWER (Dual power management)

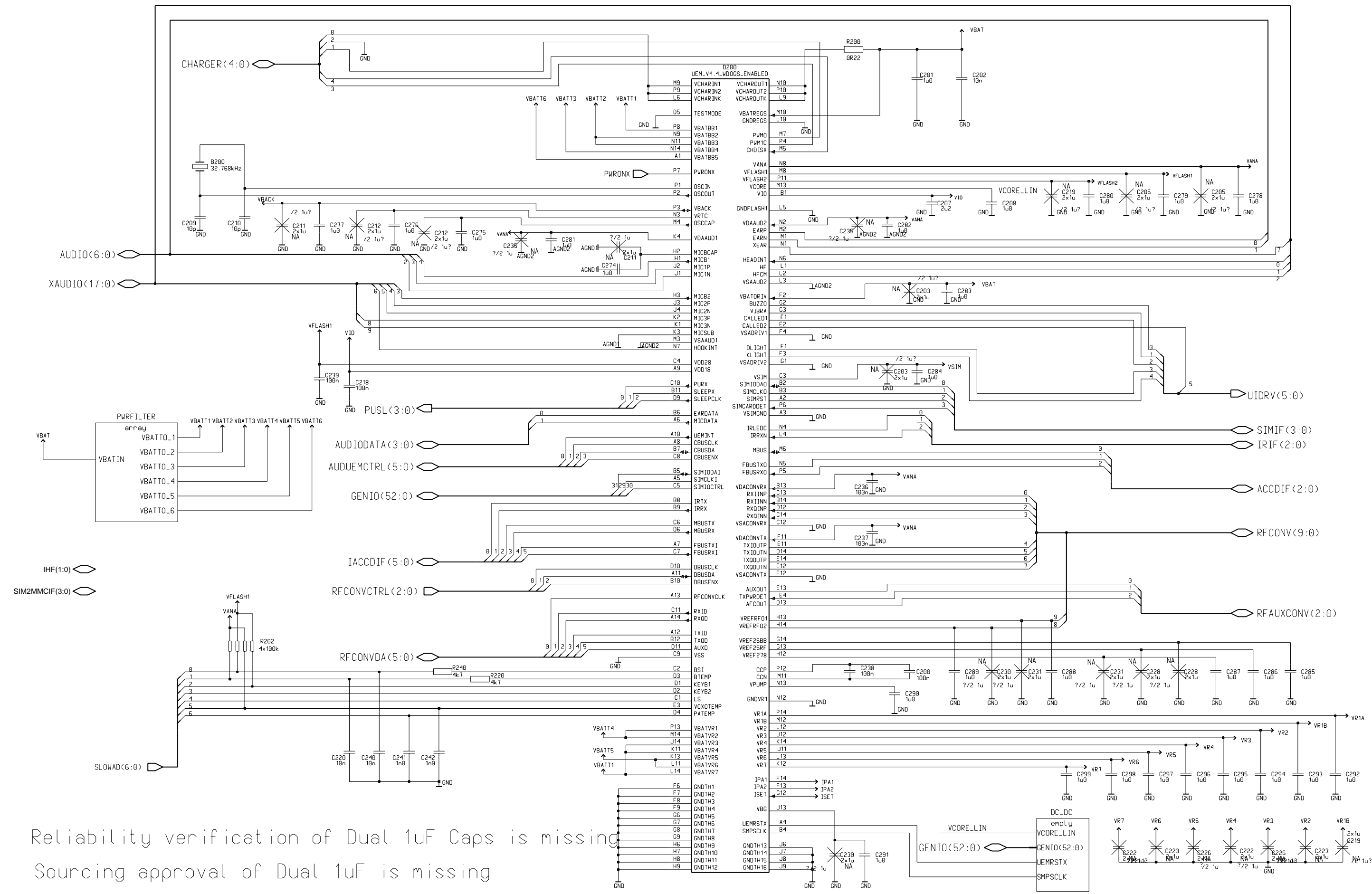

Reliability verification of Dual 1uF Caps is missing  
 Sourcing approval of Dual 1uF is missing



ac4a-14(16) DCT4 Power Supply (Light filtering)

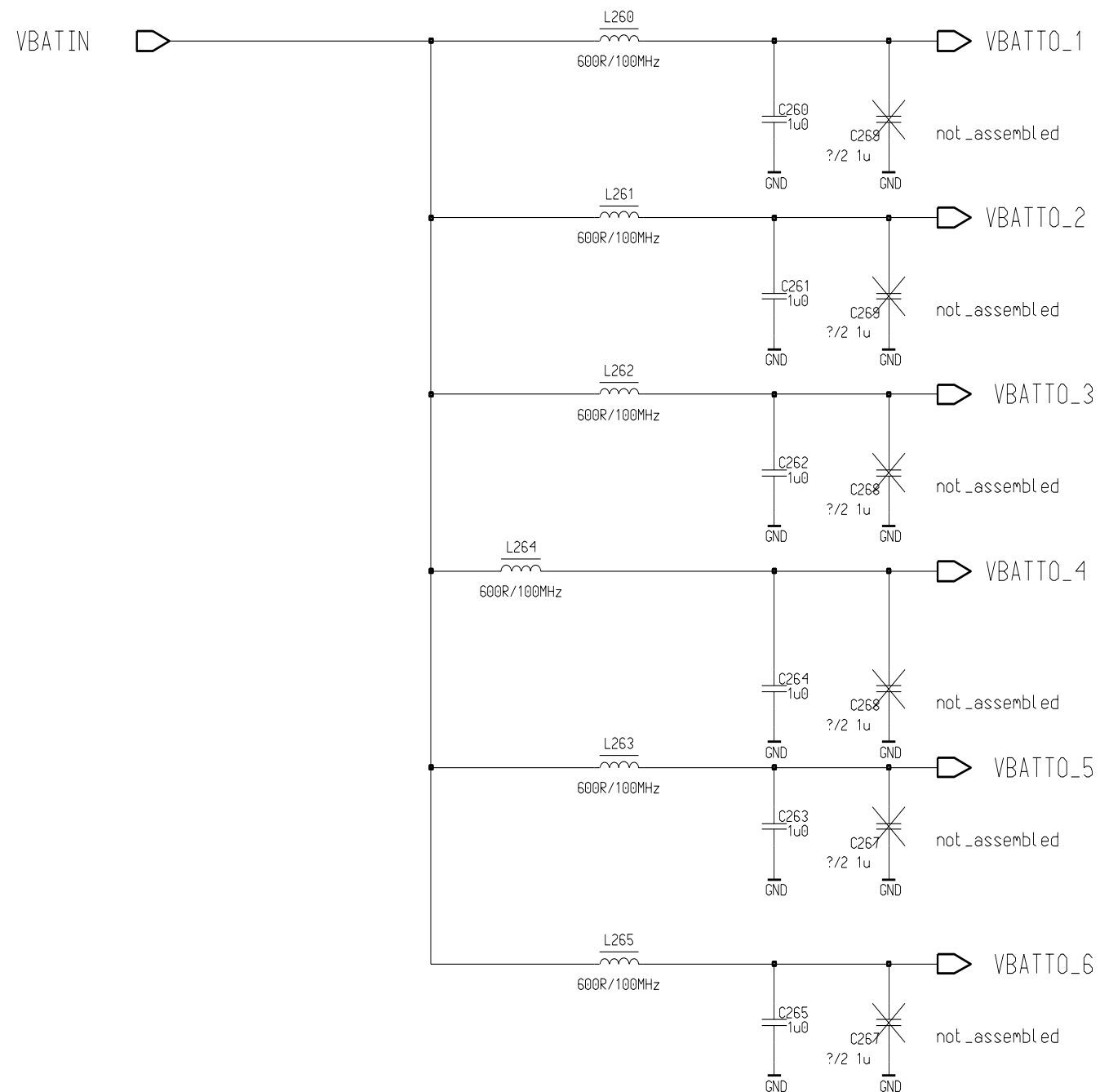

All dual capacitors have alternative discrete capacitors  
 These capacitors should be placed in layout  
 so that they will overlap

ac4a-14(17) SYS / Production Test Pattern

▷ OUT

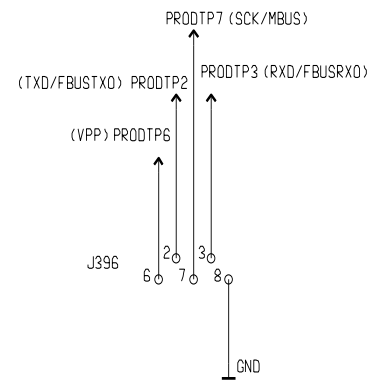

ac4a-14(18) SYS /RF - BB (GSM RF BB interface)

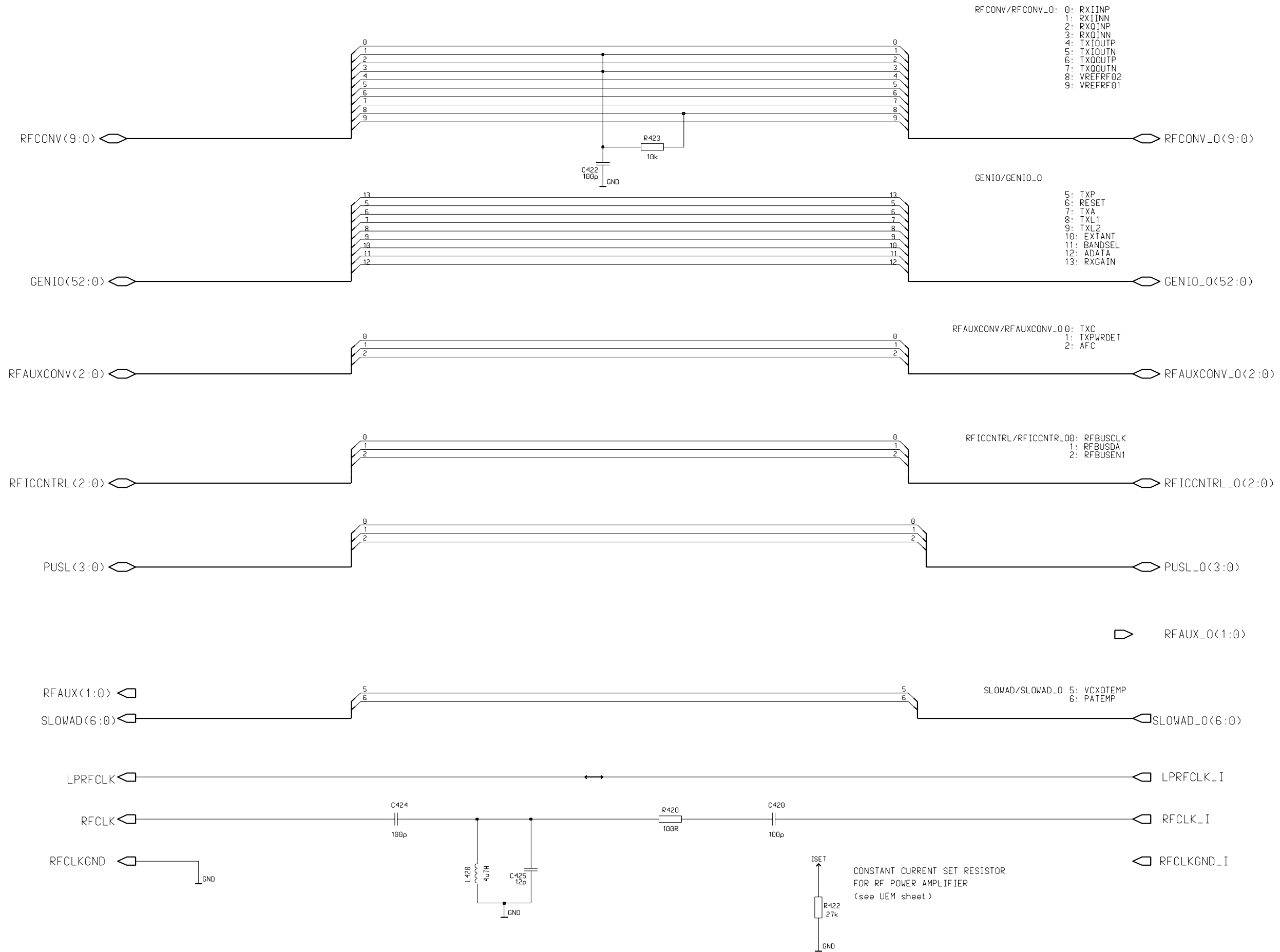

ac4a-14(19) SYS / SIM (SIM reader)

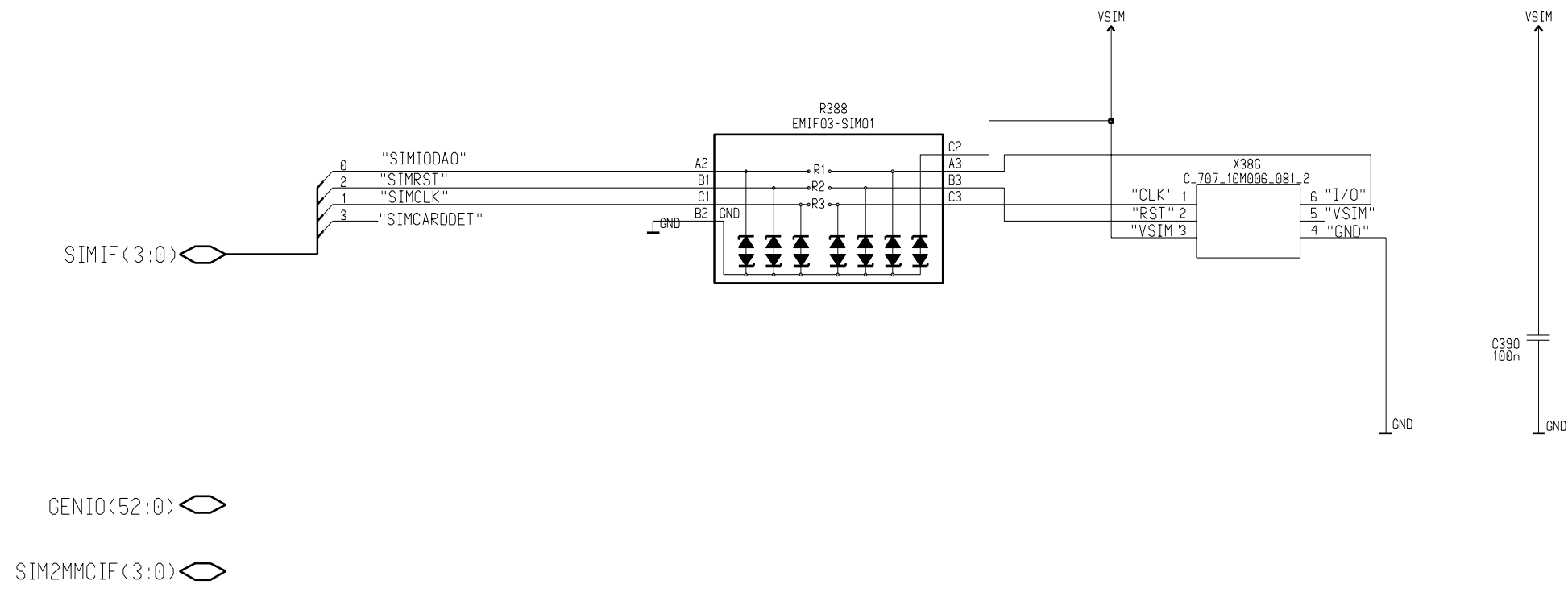

ac4a-14(20) .SYS / SYS CONN (System connector)

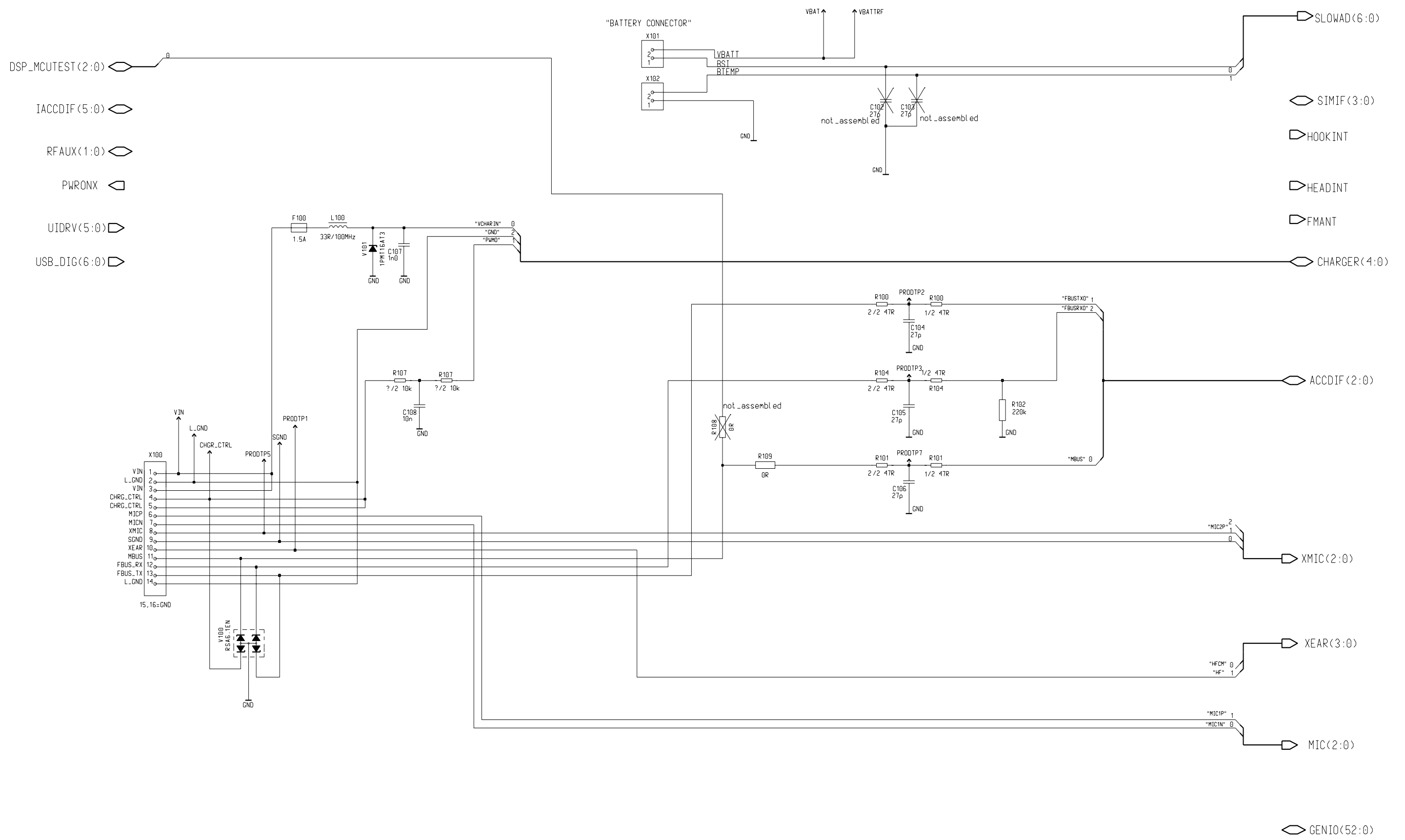

ac4a-14(21) SYS / UPP (UPP 8M implementation)

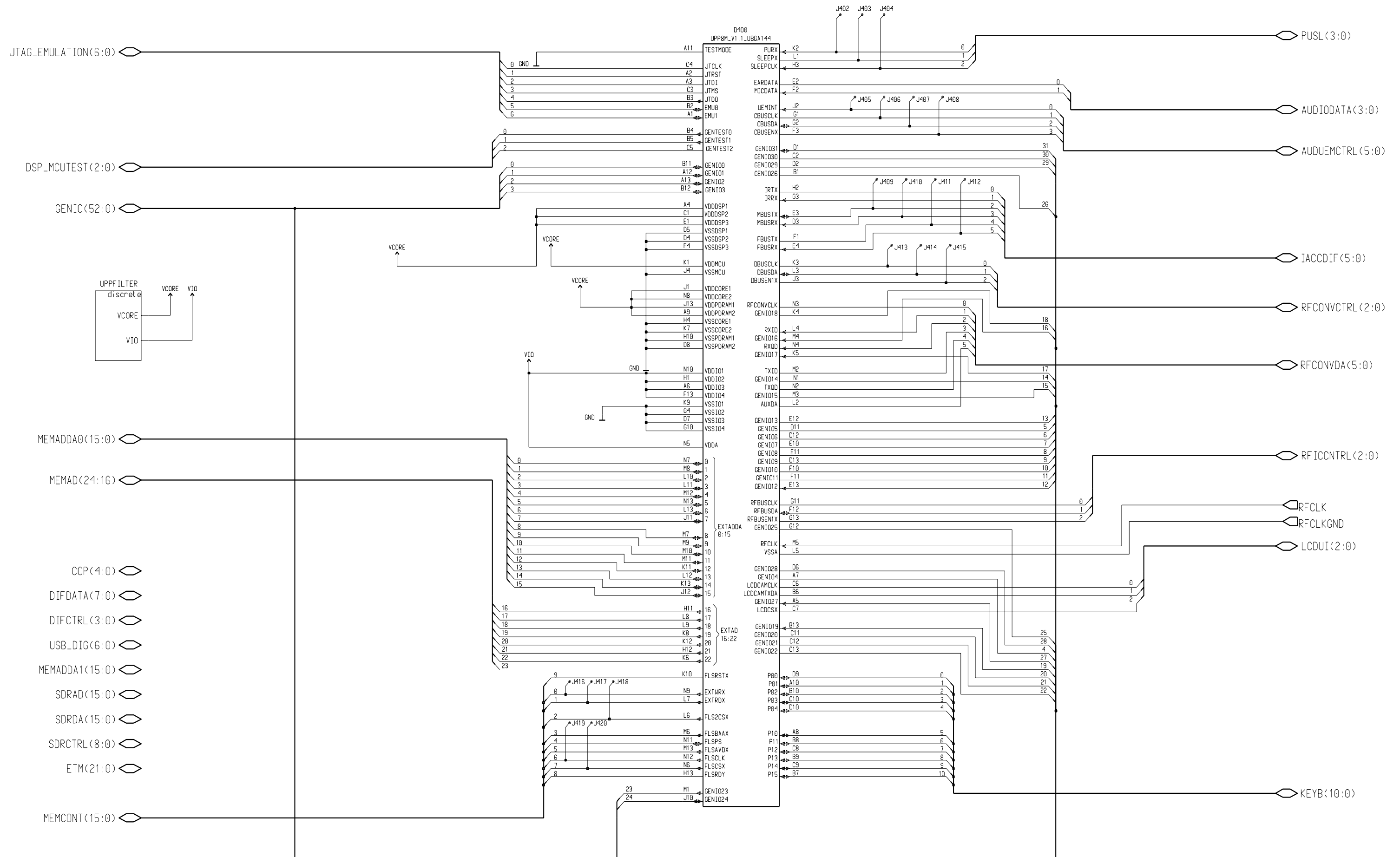

ac4a-14(22) SYS / UPP / UPP FILTER (Discrete decoupling capacitors for UPP)

